

Stainless steel Centrifugal pumps



FOR THE FOOD AND PROCESSING INDUSTRIES



BESTPUMP
Tel: 0845 467 2378
Tel: +44 (0)1236 756900 (UK)
Email: sales@bestpump.co.uk
www.bestpump.co.uk

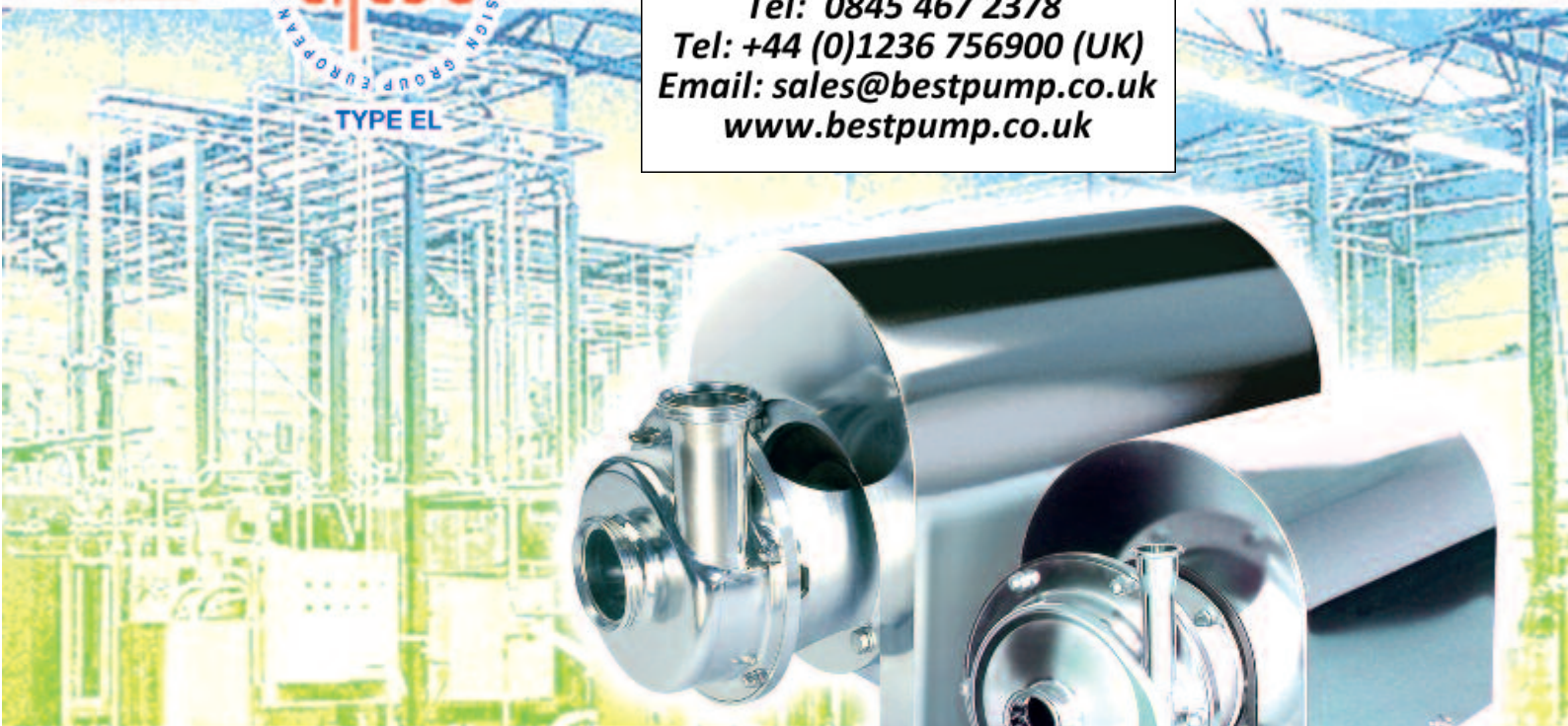

The FP2 and FP3 centrifugal pumps are the result of 50 years of experience in the manufacture of stainless steel for the food and the pharmaceutical processing industries.

They were designed according to the strictest cleanability standards. This Packo pump was the first centrifugal pump to obtain the EHEDG certificate.

The capacity range goes up to 700 m³/h, and 12 bar.

Based on the FP2 pump, there is the CRP series: an airhandling centrifugal pump which is mainly used as a CIP-return pump.

Manufacturing takes place at the ISO 9001 certified Packo plant in Diksmuide, Belgium.

Perfectly cleanable



Tel: 0845 467 2378
Tel: +44 (0)1236 756900 (UK)
Email: sales@bestpump.co.uk
www.bestpump.co.uk

MATERIAL: 316L STAINLESS STEEL AND DUPLEX

- Pump casings: thick cold-rolled plate: 100 % non porous and extremely smooth
- Impellers: investment cast, machined and electropolished

FINISH: ELECTROLYTICALLY POLISHED

This leads to:

- Extremely low micro roughness resulting in a substantially increased resistance to the adhesion of products. The result: excellent ease of cleaning and the ultimate bacteriological purity.
- A highly increased corrosion resistance due to the higher percentage of the noble materials chromium and nickel at the surface and due to the total absence of tension concentrations, caused by mechanical polishing or glass bead blasting.

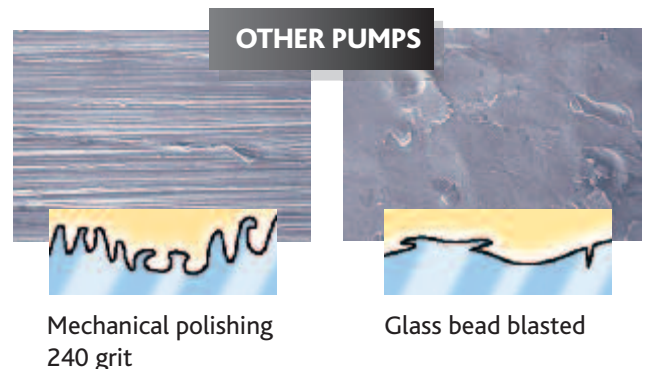

CIP-CLEANABLE

- The large seal cavity of the Packo FP2 pump is designed in such a way that there is enough turbulence to clean the inner seal (fig. 1). EHEDG tests have confirmed this. In the case of FP3 pumps with a closed impeller (fig. 2), short back blades and central openings create forced circulation (under controlled pressure) in the seal cavity.
- The impeller and the shaft are in one piece, which avoids the pumped product making contact with the shaft (no doveled or screwed machined surfaces that can be bacteria traps).



A very functional pump design

3 SEAL DIAMETERS

- Packo uses only 3 seal diameters for all pump series between 1 and 90 kW. This minimises the spare parts stock.

SEAL TYPES:

- Different seal types and materials are available depending on the application.
- Several seal configurations are optional such as: quench, double seal pressureless, double seal pressurized barrier, vacuum seals, etc.



STANDARD COMPONENTS



- The mechanical seals and pump casing seals are all standard components and they are available all over the world.
- The motors are also standard (IEC or NEMA). In this way, the pump can without any problem be factory fitted or subsequently changed to have motors with special characteristics (explosion proof, special voltage, special dimensions, integrated frequency converter, etc.).



GENTLE PRODUCT HANDLING

- Volute type casing leading to higher efficiency, less turbulence and hence reduced risk of product damage.



LOW VIBRATION – LOW NOISE

- Stainless steel motor shrouds on larger motors are mounted on shock absorbers.
- Adjustable feet executed with rubber sole (Optional).

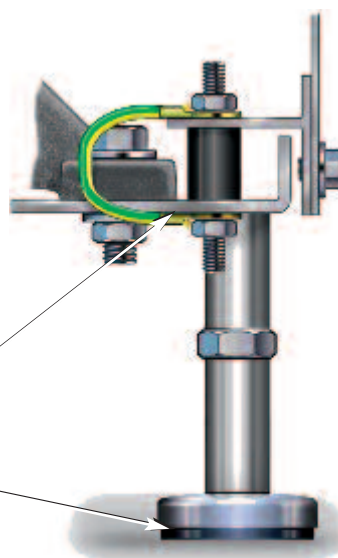

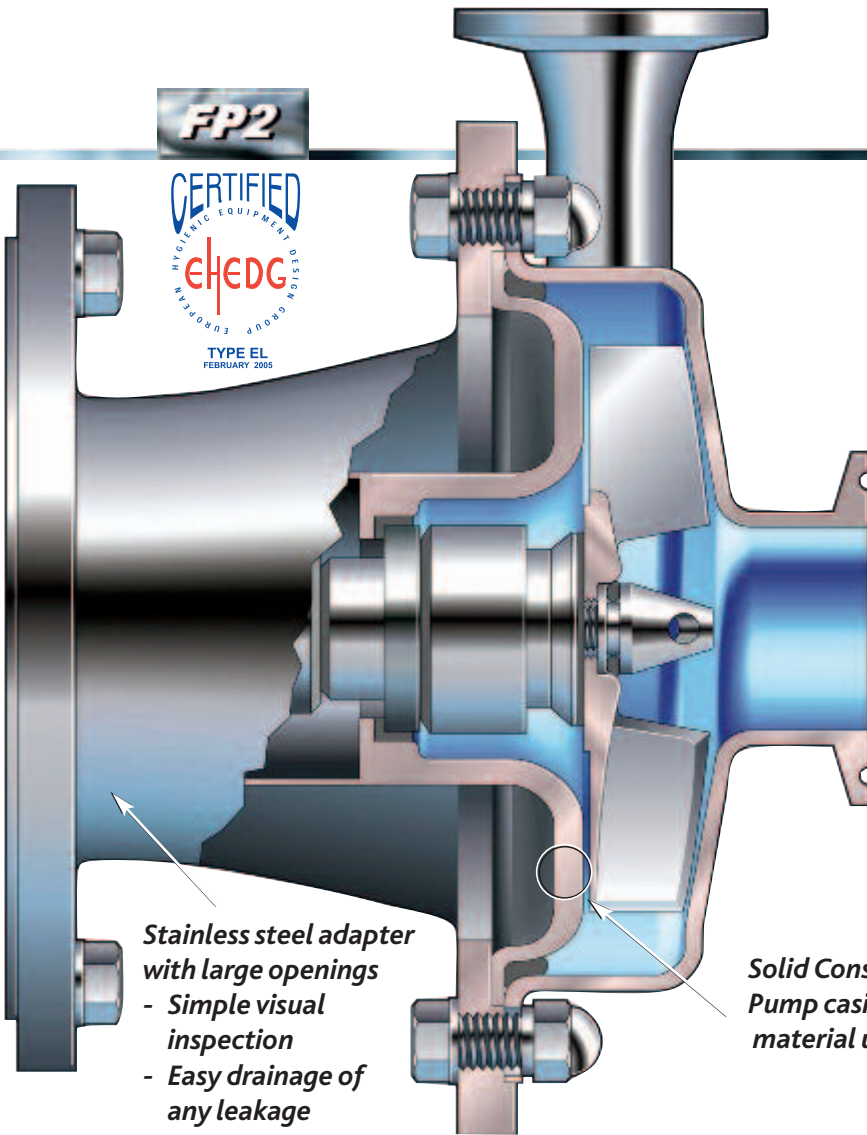

FP2
CERTIFIED
 HYGIENIC EQUIPMENT DESIGN
eHEDG
 EUROPEAN HYGIENIC EQUIPMENT DESIGN GROUP
 TYPE EL
 FEBRUARY 2005

Stainless steel adapter with large openings

- Simple visual inspection
- Easy drainage of any leakage

Solid Construction
 Pump casing and backplate produced from material up to 30 mm thick

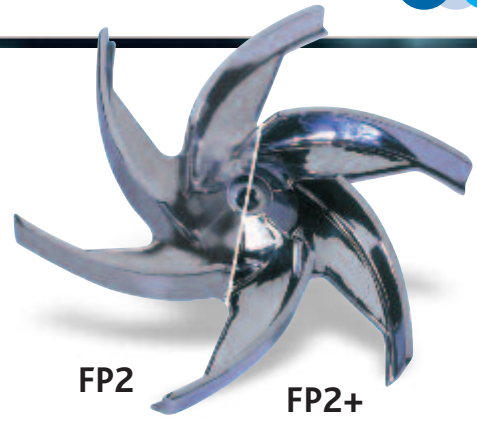

FP2 **FP2+**

OPEN IMPELLER

- Low NPSH values
- Excellent air handling
- Non clogging
- No axial stress on the motor bearings
- Low pressure in seal cavity: extended seal life



FP3
CERTIFIED
 HYGIENIC EQUIPMENT DESIGN
eHEDG
 EUROPEAN HYGIENIC EQUIPMENT DESIGN GROUP
 TYPE EL
 OCTOBER 2004

CLOSED IMPELLER

- With double curved blades
- Extra low NPSH values
 - High efficiency
 - Short back blades eliminate the axial stress on the motor bearings and cause controlled pressure on the seal.

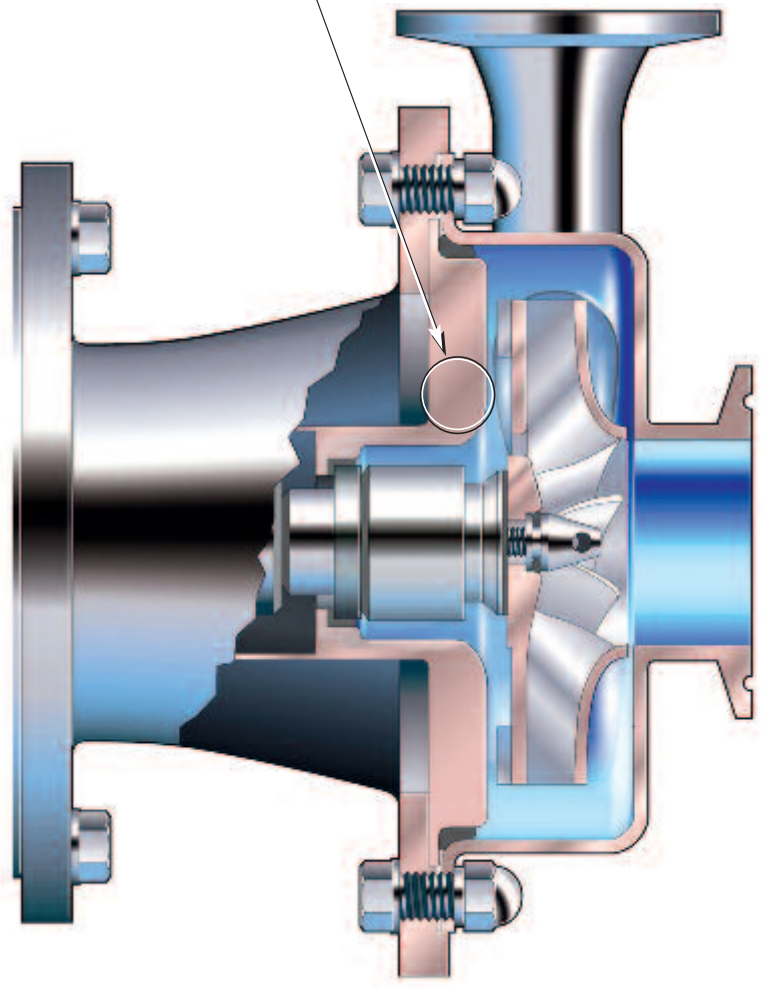

Field of application



The FP pumps are mainly used in the food, pharmaceutical, cosmetic, agricultural and fine chemical industries, where clean or slightly charged, polluted, abrasive or viscous liquids are to be transferred. Some actual applications are: milk, egg, soya, beer, wort, wine, fruit juices, soft-drinks, alcohol, yeast, starch, vegetable and ethereal oils, sugar solutions, brine, blood, light chemicals, solvents, detergents, demineralised water and CIP solutions.

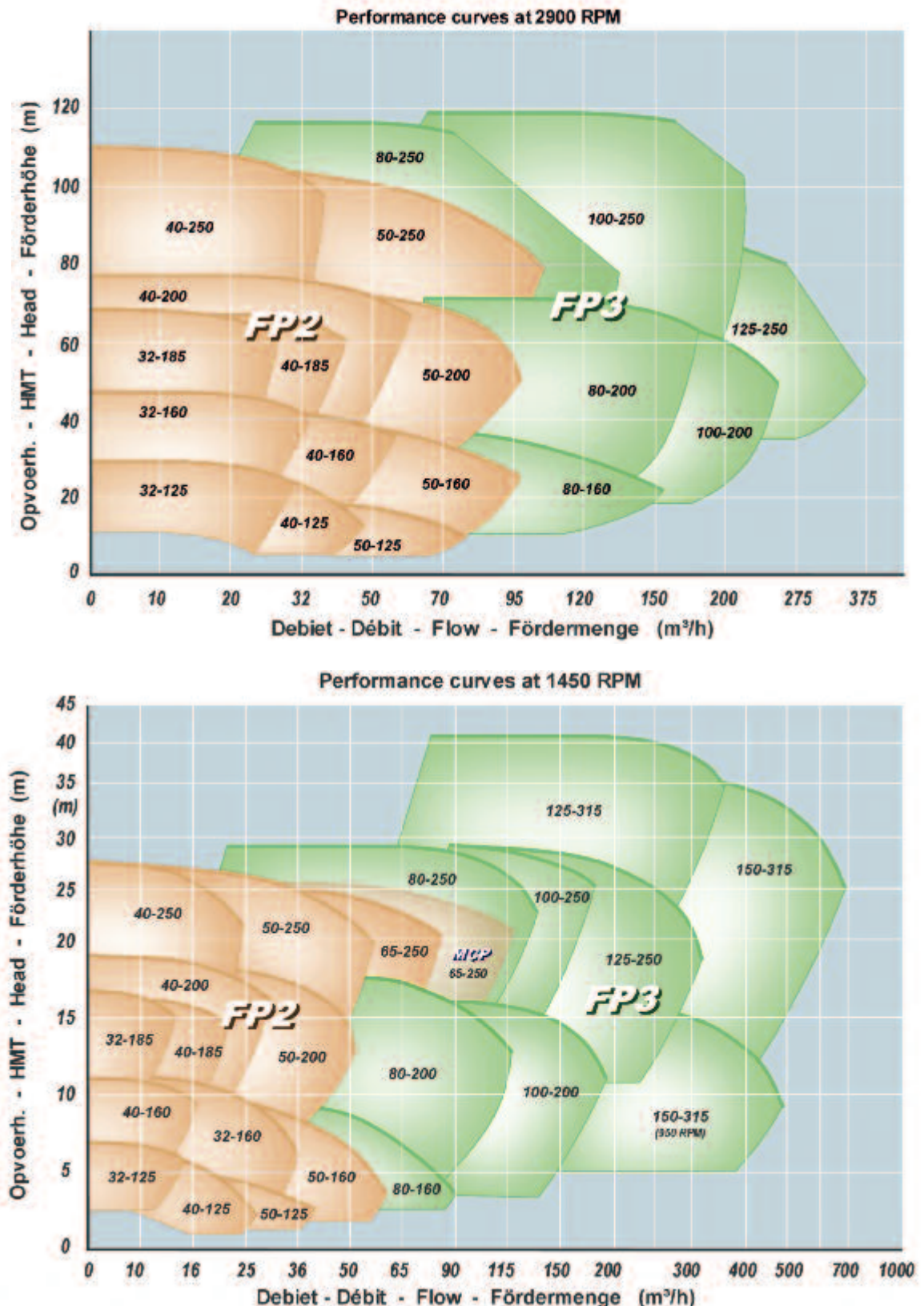

Selfpriming and air handling pumps

CIP-RETURN PUMP **CRP**

The **CRP** series, based on the FP2 pump is an air handling centrifugal pump which is mainly used as a CIP-return and tanker unloading pump. This pump consists of the same components as the FP2 pumps. Only the pump casing is different, i.e. the same impeller, the same seals, etc.

ADVANTAGES

- Large clearances between the impeller and the pump casing allow small impurities to pass without causing wear (contrary to liquid ring pumps). As a consequence, the pump performance remains the same even after several years of operation.
- Lower NPSH values and higher efficiency compared with liquid ring pumps.
- Flat head-flow curve. The pump can run against closed valve without providing extra high pressure or absorbing more power.
- Low noise.
- The pump can be supplied in a pharmaceutical version.

MODULAR

The **FP** and **CRP** series consist of the same components. Only the pump casing is different. This minimises the spare parts stock.

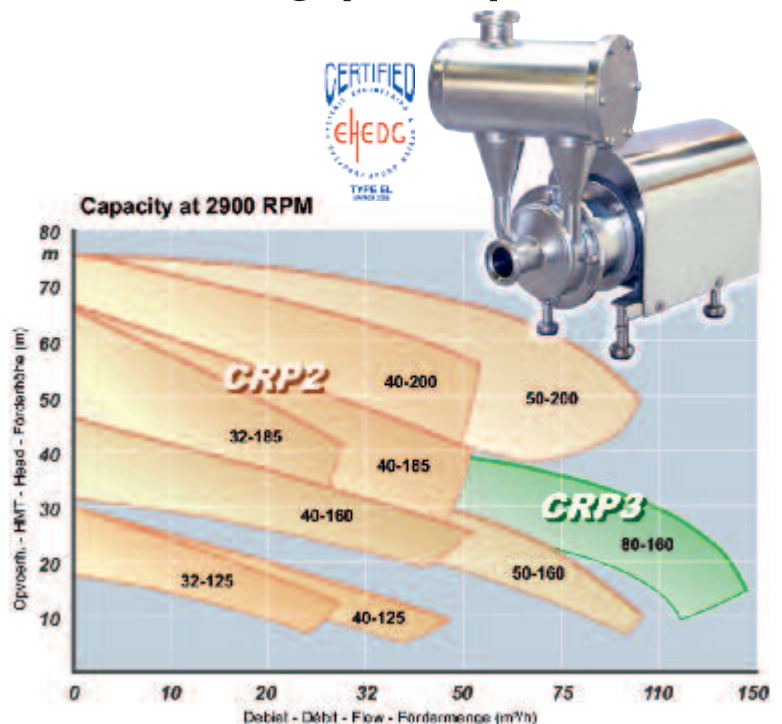
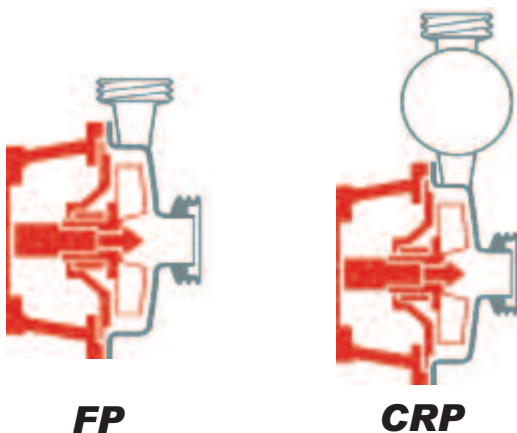

OTHER PUMPS FOR FOOD INDUSTRY

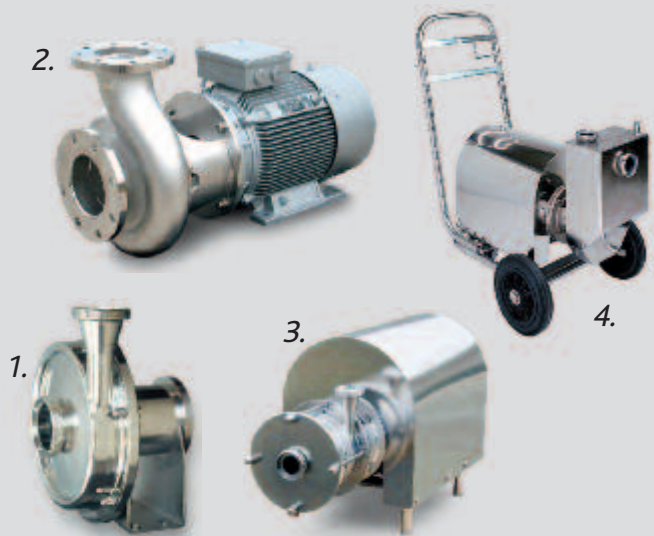

1. Milk collecting pumps **FP2** and **MCP2** for hydraulic motor assembly
2. High capacity **MCP3** pumps
3. Multistage pumps **FMS**
4. Self Priming pumps **SCP2**