

DEPA Air Driven Diaphragm Pumps

Series M Type DL Cast Metal Pumps



For general industrial, water/waste, construction and mining duties.

Many years experience in the design and manufacture of air driven diaphragm pumps have resulted in these high performance units. Because of their compact, lightweight construction, they are well suited to portable and mobile applications as well as fixed installation in process plants.

All types of fluids from water to slurries and pastes, including abrasive or shear sensitive media containing solids, are handled cost effectively by these pumps.

Choice of just the right Series M unit to satisfy the requirement in each case is facilitated by availability of three different materials for the pump housing:

- * Cast Aluminium, AL 233
- * Ductile Iron, GGG 40
- * Cast Stainless Steel, 1.4408 (SS 316)

Series M pumps are manufactured in five different sizes with standard connections: DN 15 to DN 80, (½ in. to 3 in.)

All models are completely self contained, only requiring connection to pipework and air supply.

Standard design

Features include maintenance free control valve, stainless steel base with integral anti vibration mounts, drain and vent connections, stainless steel clamp bands, air intake filter (for DL25 to DL80) and muffler.

Accessories

A complete range of accessories simplifies operation and enhances flexibility.

They include pulsation dampeners, monitoring and control systems, various transport devices, quick release couplings, adapters etc.

For more information, please contact your local supplier.

- Ideal for abrasive, viscous and shear sensitive media, and for products with entrained solids.
- Tolerance of dry running and harsh usage.
- Minimal maintenance with no lubrication required.
- Positive displacement pumping action minimises product shear.
- Completely enclosed units with no bearings or rotary seals in the product stream.
- Air operation means suitability for explosive or hazardous areas.
- Easy control of flow rate by regulating air supply.
- No need for electric motors, special drives or base plates.
- Easily portable and ready to use by simply connecting to air supply.
- Can be run against a closed discharge—a vital benefit for use on filling machines.
- Self priming and submersible.
- Rugged construction in cast aluminium, ductile iron or cast stainless steel.

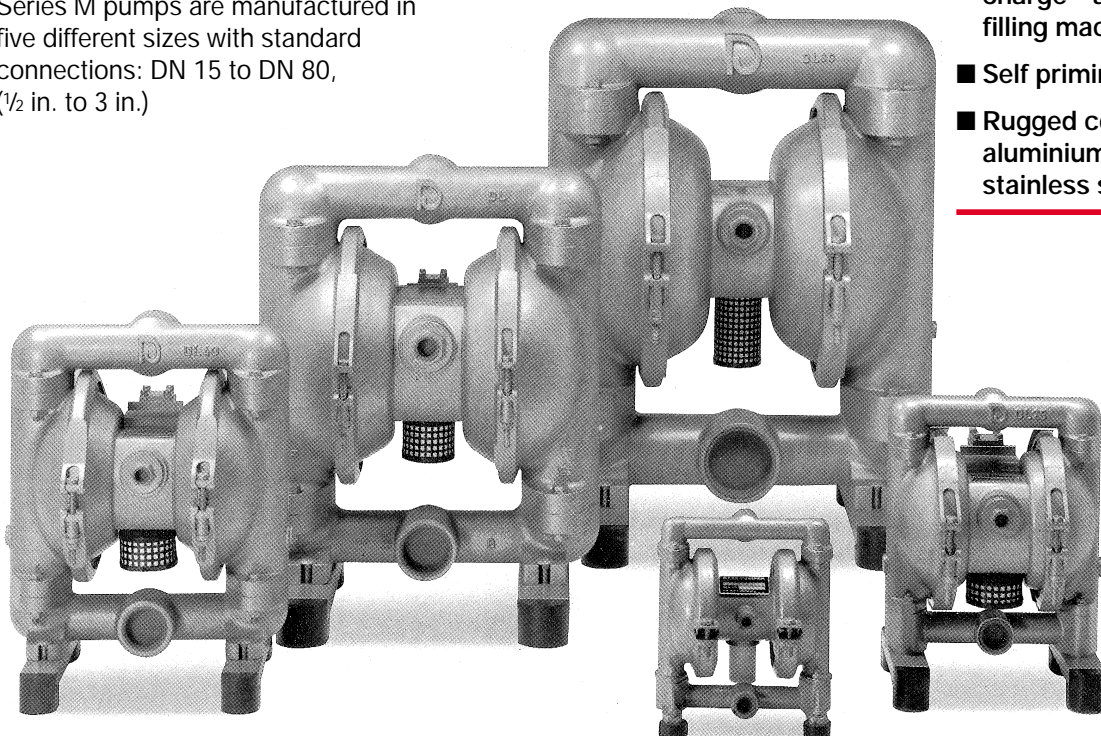

DEPA Air Driven Diaphragm Pumps

Series M Type DL Operating Principle

Double acting, positive displacement Series M pumps operate with two alternating pumping chambers. The compressed air which drives the unit is admitted through a control valve, to the rear of each diaphragm in turn, so displacing the medium from alternate pumping chambers.

In the pump illustrated, the right hand pumping chamber is in the intake position. A vacuum has been created

by the retraction of the diaphragm and the pumped medium flows into the chamber. The left hand diaphragm, which is supported by compressed air, simultaneously displaces the medium present in this chamber.

Since the two diaphragms are connected by a common piston rod, suction always occurs in one chamber whilst discharge is occurring in the other.

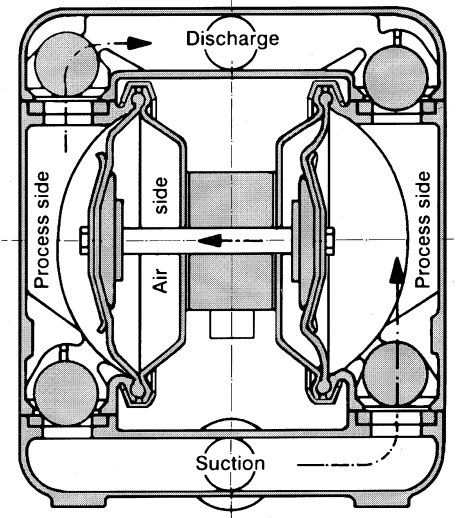

Materials of construction available as standard series

DL 40 - SA - TTT

Pump size	Major subassemblies			Internals	Diaphragm	Seats	Balls		
	Housing	Wetted piston	Centre block						
Connections 1/2 in. DN 15	15	Cast aluminium	Steel	Cast aluminium	AA	NRS	B	B	B
Connections 1 in. DN 25	25	Cast aluminium	Stainless steel AISI 321 (1.4541)	Cast aluminium	FA	NBR (Buna N)	N	N	N
Connections 1 1/2 in. DN 40	40					EPDM (Nordel)	E	E	E
Connections 2 in. DN 50	50	Ductile iron	Steel	Cast aluminium	CA	EPDM (High press.)	D	-	-
Connections 3 in. DN 80	80					EPDM (grey)	G	-	G
		Ductile iron	Steel	Cast aluminium	CA	FKM (Viton)	F	F	-
						PTFE (Teflon)	T	T	T
		Cast stainless steel AISI 316 (1.4408)	Stainless steel AISI 321 (1.4541)	Cast aluminium	SA	Ceramic ¹⁾	-	-	K
						EPDM grey for Type DH	U	-	-
		Cast stainless steel AISI 316 (1.4408)	Stainless steel AISI 321 (1.4541)	Cast bronze	SX	PTFE for Type DH	P	-	-
						Stainless steel	-	-	R
						NBR, steel core	-	-	Y
						EPDM, steel core	-	-	W
						EPDM, grey with steel core	-	-	X
						PTFE, steel core	-	-	Z
						Conical valve, EPDM	-	E	I

¹⁾ For DL15 only

Particle size and suction lift					
Pump size	15	25	40	50	80
Particle size mm	3.5	4	6	8	10
Suction lift in mWC dry ²⁾	3.5	5.5	5.8	5.8	6
Wetted	9	8.7	9	9	9

Maximum operating temperature		°C
Metal pumps with internal components of	NRS	80
	NBR, EPDM	100
	FKM	140
	PTFE	110

²⁾ For pumps equipped with valve seats and valve balls of PTFE and those with cone valves, a decrease in suction lift must be expected.

Pump weight in kg	Housing type				
	FA	CA	CX	SA	SX
Pump size					
15	3	-	-	-	-
25	7	11	11	12	12
40	13	21	23	21	23
50	30	46	49	46	49
80	55	96	100	96	100

Performance characteristics of Series M Type DL cast metal models

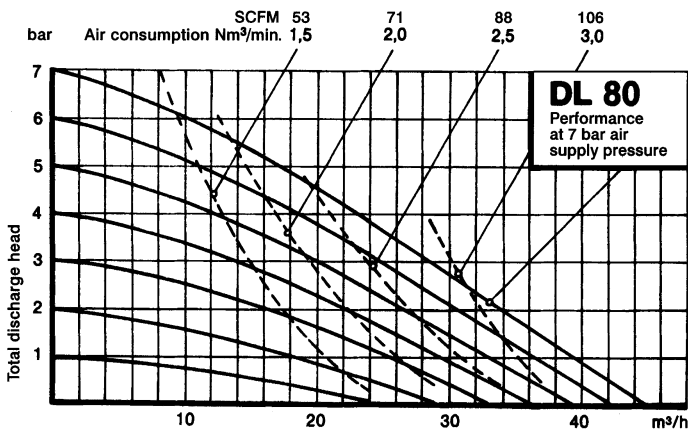
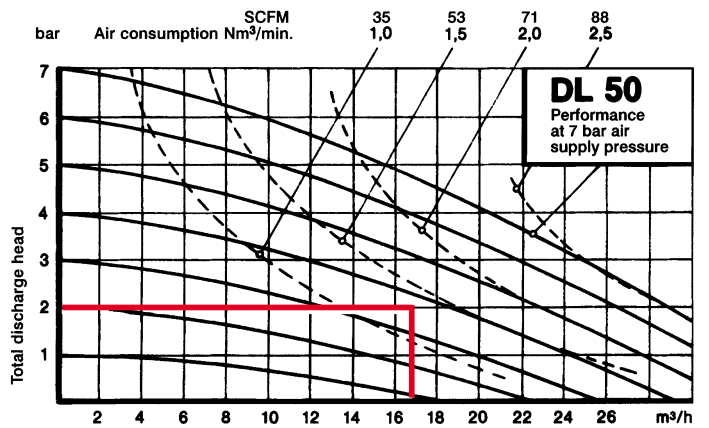
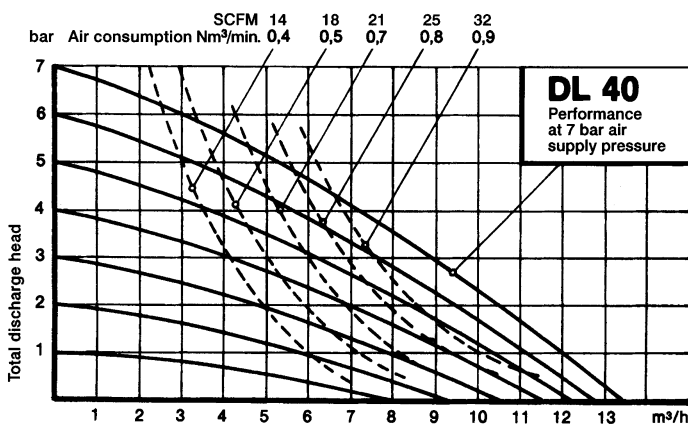
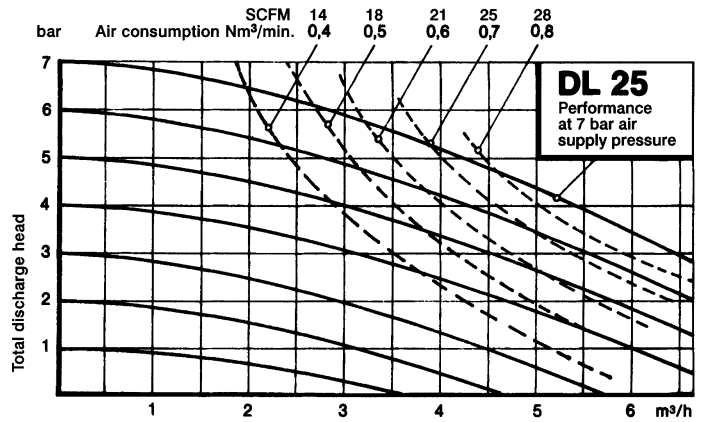
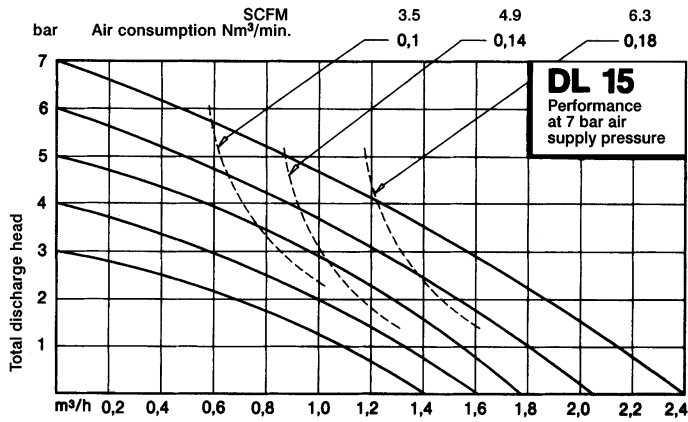

Example: To help you select the correct pump size

Required pumping rate is 17 m³/h and required total discharge head is 20m. The correct selection is DL 50, the required air pressure is 3.8 bar and the air consumption is 1.5 Nm³/min.

BESTPUMP

Tel: 0845 467 2378
Tel: +44 (0)1236 756900 (UK)
Email: sales@bestpump.co.uk
www.bestpump.co.uk

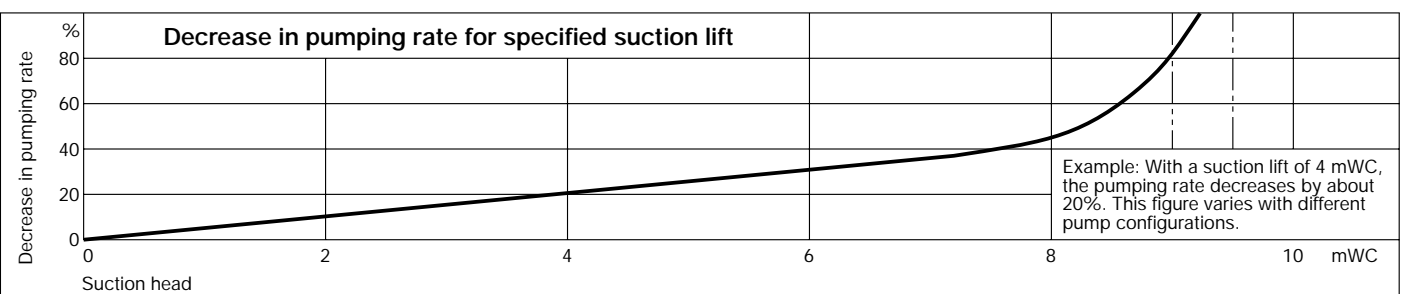
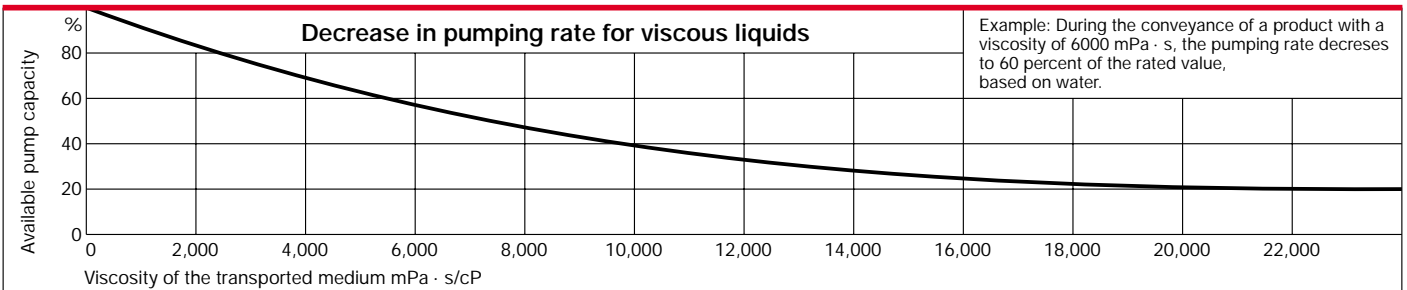

Extremely rugged construction reduces downtime to a minimum.

DEPA pumps have been designed in such a way that all components in contact with the product can be disassembled and reassembled within a few minutes. This means that servicing work is reduced to the absolute minimum.

DEPA air driven diaphragm pumps have been developed as a modular system. Consequently, many components—some of which are common to all versions—are mutually compatible and interchangeable.

This flexible construction allows quick and simple changing of the internals for all Type DL models, to fulfil different applications.

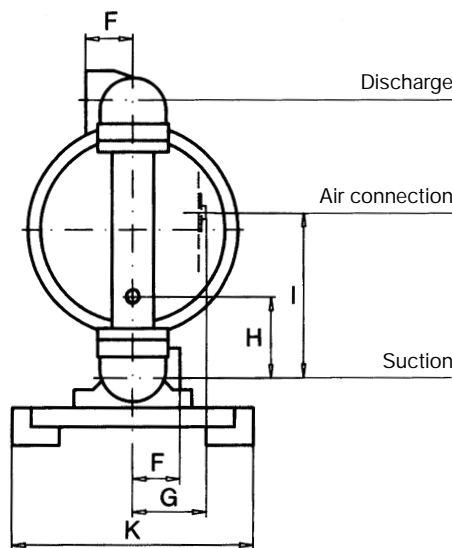
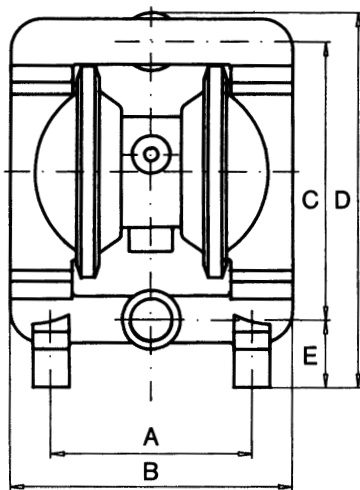
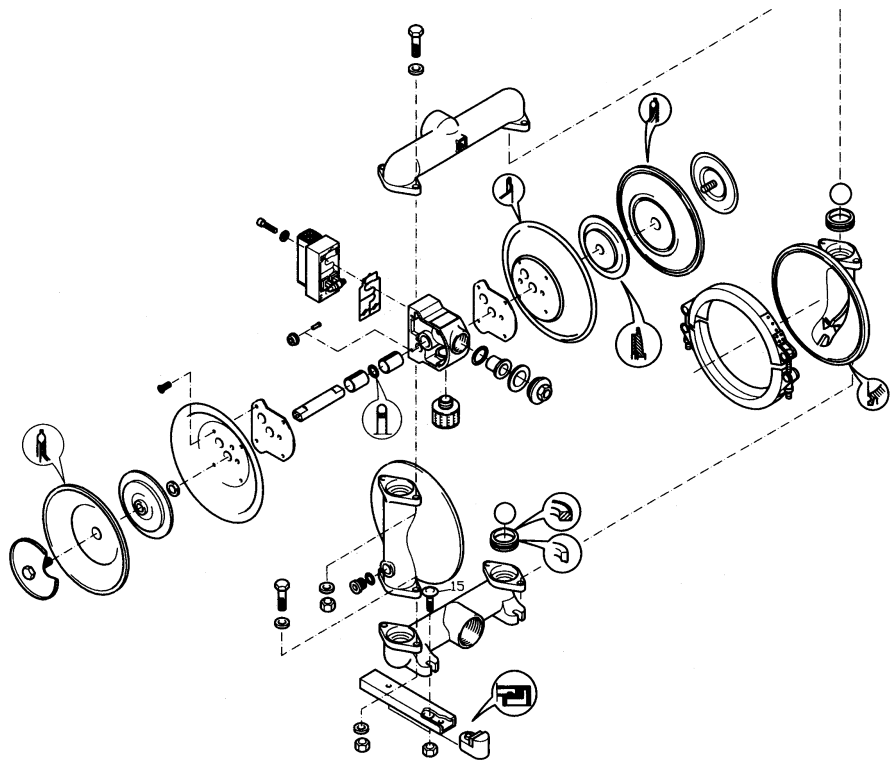

Dimensions for all cast metal sizes

	Size				
	15	25	40	50	80
A	156	190	220	280	350
B	190	236	310	412	512
C	180	241	305	414	522
D	225	322	406	540	680
E	31	61	72	88	105
F	28	35	50	65	80
G	34	84	84	105	105
H	-	71	93	125	160
I	90	141	179	245	304
K	120	200	255	340	420
Air connection	¼ in.	⅜ in.	½ in.	¾ in.	¾ in.

All dimensions shown in mm

There is a DEPA diaphragm pump for practically every liquid that flows.

DEPA air driven diaphragm pumps are available in three different basic con-

structions: cast metal, solid plastic and highly polished stainless steel (CIP compatible). Special purpose designed models are available for powders, high pressures up to 21 bar

and drum pumping of hard-to-handle drum contents.

For more information please contact your local supplier.